

Module 2 Stresses in machine elements

Lesson 1 Simple stresses

Instructional Objectives

At the end of this lesson, the student should have adequate knowledge of

- Simple stresses in machine elements; tensile, compressive, bearing and shear stresses.
- Flexure formula and their limitations.
- Torsion formula and its limitations.
- Design of members subjected to combined bending, torsion and axial loading.
- Buckling of beams.

2.1.1 Introduction

Stresses are developed in machine elements due to applied load and machine design involves ensuring that the elements can sustain the induced stresses without yielding. Consider a simple lever as shown in figure-2.1.1.1:

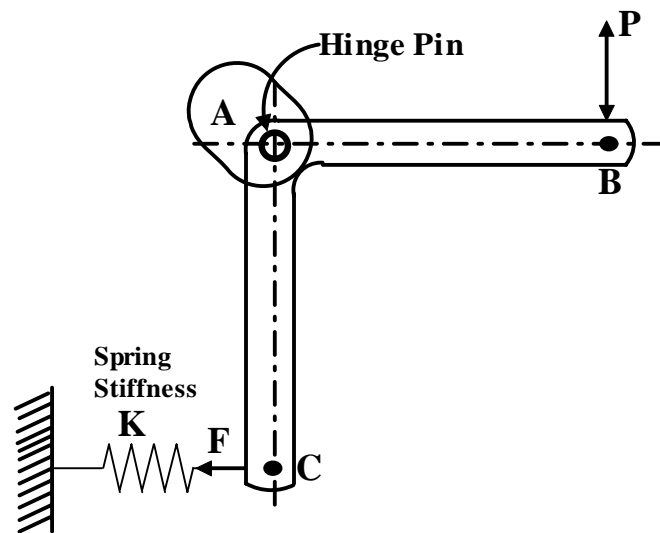

2.1.1.1F- A simple lever subjected to forces at the ends.

A proper design of the spring would ensure the necessary force P at the lever end B. The stresses developed in sections AB and AC would decide the optimum cross-section of the lever provided that the material has been chosen correctly.

The design of the hinge depends on the stresses developed due to the reaction forces at A. A closer look at the arrangement would reveal that the following types of stresses are developed in different elements:

- Lever arms AB and AC - Bending stresses
- Hinge pin - Shear and bearing stresses.
- Spring - Shear stress.

It is therefore important to understand the implications of these and other simple stresses. Although it is more fundamental to consider the state of stress at a point and stress distribution, in elementary design analysis simple average stresses at critical cross-sections are considered to be sufficient. More fundamental issues of stress distribution in design analysis will be discussed later in this lecture.

2.1.2 Some basic issues of simple stresses

Tensile stress

The stress developed in the bar (figure-2.1.2.1) subjected to tensile loading is

given by $\sigma_t = \frac{P}{A}$

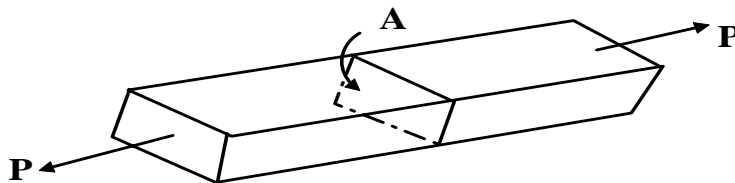

2.1.2.1F- A prismatic bar subjected to tensile loading.

Compressive stress

The stress developed in the bar (figure-2.1.2.2) subjected to compressive loading is given by

$$\sigma_c = \frac{P}{A}$$

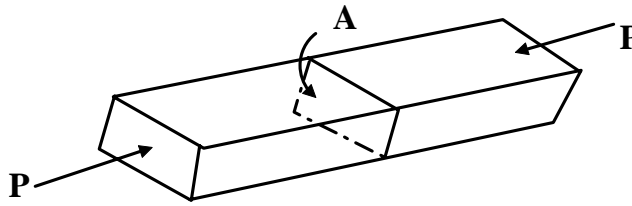

2.1.2.2F- A prismatic bar subjected to compressive loading.

Here the force P is the resultant force acting normal to the cross-section A . However, if we consider the stresses on an inclined cross-section B (figure- 2.1.2.3) then the normal stress perpendicular to the section is

$$\sigma_{\theta} = \frac{P \cos \theta}{A / \cos \theta}$$

and shear stress parallel to the section

$$\tau = \frac{P \sin \theta}{A / \cos \theta}$$

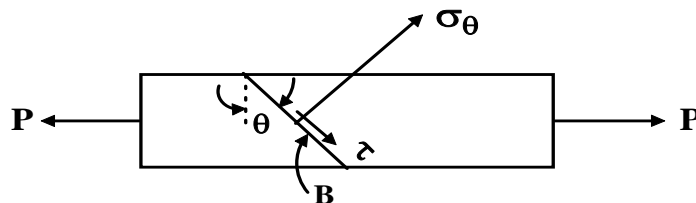

2.1.2.3F- Stresses developed at an inclined section of a bar subjected to tensile loading.

Bearing stress

When a body is pressed against another, the compressive stress developed is termed bearing stress. For example, bearing stress developed at the contact between a pillar and ground (figure- 2.1.2.4a) is $\sigma_{br} = \frac{P}{A}$, at the contact surface between a pin and a member with a circular hole (figure- 2.1.2.4b) is $\sigma_{br} = \frac{P}{Ld}$ and at the faces of a rectangular key fixing a gear hub on a shaft (figure- 2.1.2.4c) is $\sigma_{br} = \frac{4T}{aLd}$.

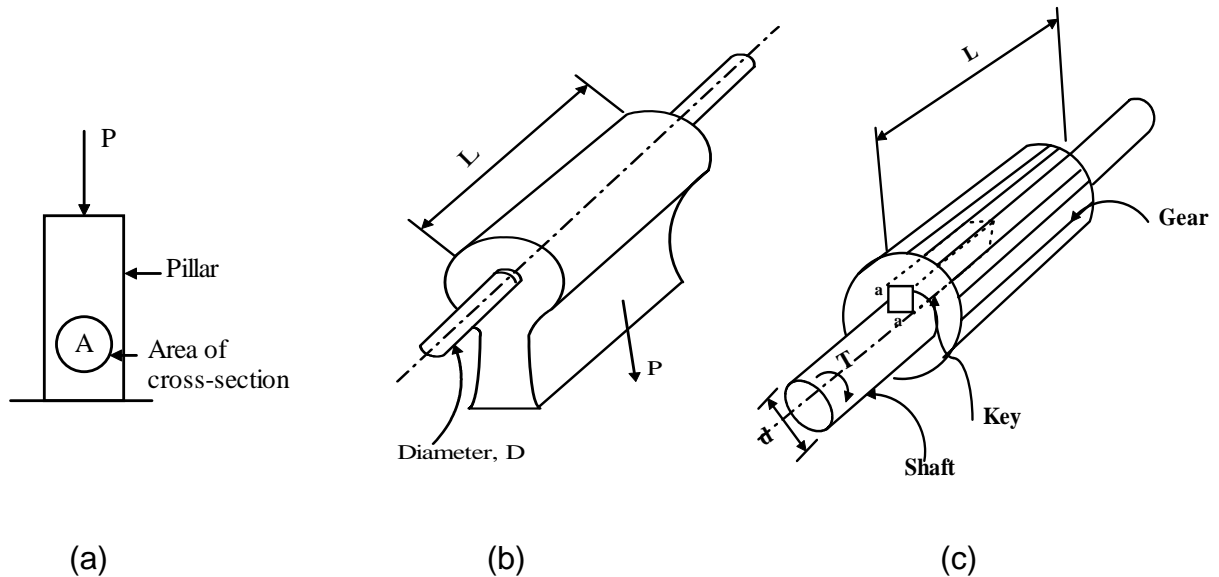

2.1.2.4F- The bearing stresses developed in pillar and machine parts.

The pressure developed may be irregular in the above examples but the expressions give the average values of the stresses.

Shear stress

When forces are transmitted from one part of a body to other, the stresses developed in a plane parallel to the applied force are the shear stresses (figure- 2.1.2.5) and the average values of the shear stresses are given by

$$\tau = \frac{P}{A} \quad \text{in single shear}$$

$$\tau = \frac{P}{2A} \quad \text{in double shear}$$

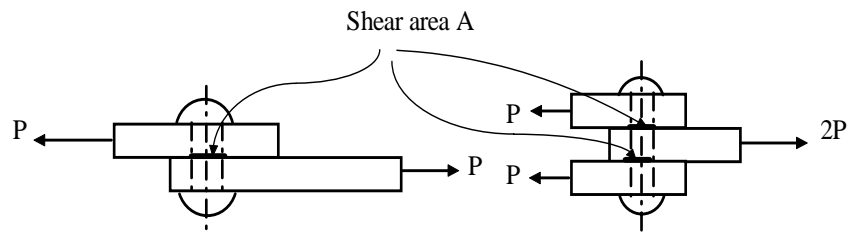

2.1.2.5F- Stresses developed in single and double shear modes

In design problems, critical sections must be considered to find normal or shear stresses. We consider a plate with holes under a tensile load (figure-2.1.2.6) to explain the concept of critical sections.

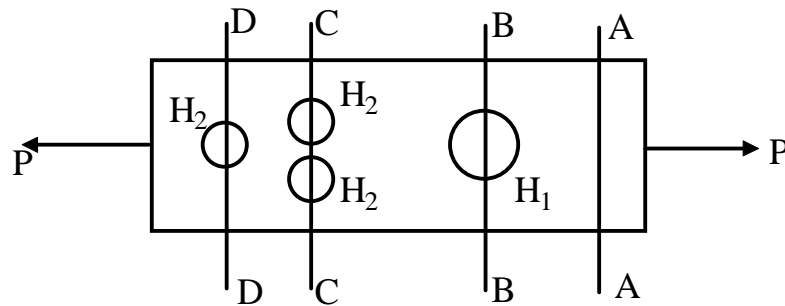

2.1.2.6F- The concept of critical sections explained with the help of a loaded plate with holes at selected locations.

Let the cross-sectional area of the plate, the larger hole H_1 and the smaller holes H_2 be A , a_1 , a_2 respectively. If $2a_2 > a_1$ the critical section in the above example is CC and the average normal stress at the critical section is

$$\sigma = \frac{P}{A - 2a_2}$$

2.1.3 Bending of beams

2.1.3.1 Bending stresses

Consider two sections ab and cd in a beam subjected to a pure bending. Due to bending the top layer is under compression and the bottom layer is under tension. This is shown in figure-2.1.3.1.1. This means that in between the two extreme layers there must be a layer which remains un-stretched and this layer is known as neutral layer. Let this be denoted by NN' .

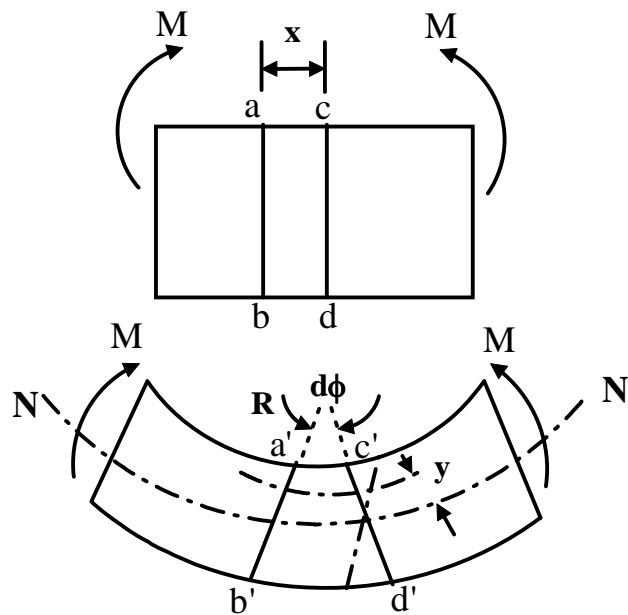

2.1.3.1.1F- Pure bending of beams

We consider that a plane section remains plane after bending- a basic assumption in pure bending theory.

If the rotation of cd with respect to ab is $d\phi$ the contraction of a layer y distance away from the neutral axis is given by $ds = y d\phi$ and original length of the layer is $x = R d\phi$, R being the radius of curvature of the beam. This gives the strain ϵ in the layer as

$$\varepsilon = \frac{y}{R}$$

We also consider that the material obeys Hooke's law $\sigma = E\varepsilon$. This is another basic assumption in pure bending theory and substituting the expression for ε we have

$$\frac{\sigma}{y} = \frac{E}{R}$$

Consider now a small element dA y distance away from the neutral axis. This is shown in the figure 2.1.3.1.2

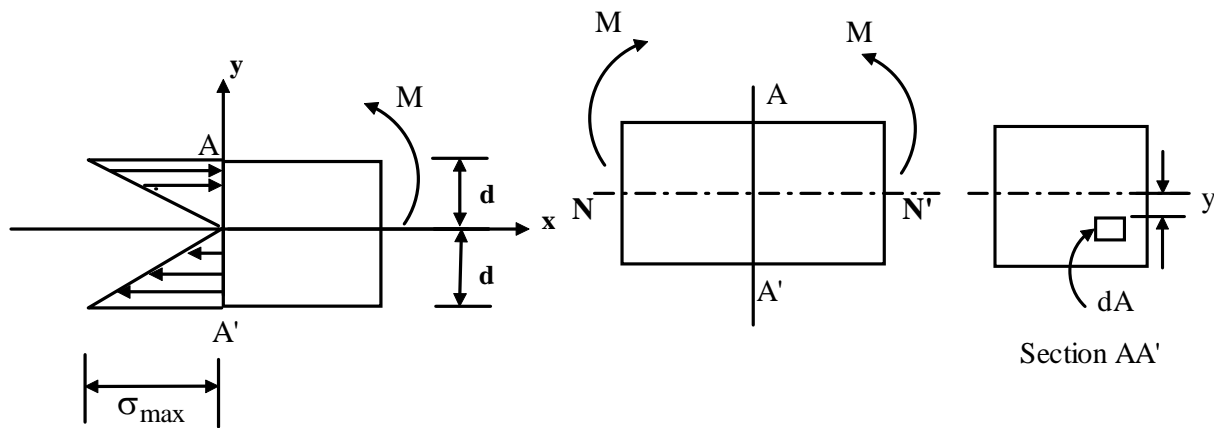

2.1.3.1.2F- Bending stress developed at any cross-section

Axial force on the element $dF_x = \sigma_x dA$ and considering the linearity in stress variation across the section $\frac{\sigma_x}{\sigma_{\max}} = \frac{y}{d} = \frac{y}{d}$ we have where σ_x and σ_{\max} are the stresses at distances y and d respectively from the neutral axis.

The axial force on the element is thus given by $dF_x = \frac{\sigma_{\max} y}{d} dA$.

For static equilibrium total force at any cross-section $F = \int_A \frac{\sigma_{\max} y}{d} y dA = 0$

This gives $\int_A y dA = \bar{y} A = 0$ and since $A \neq 0, \bar{y} = 0$. This means that the neutral axis passes through the centroid.

Again for static equilibrium total moment about NA must be the applied moment M .

This is given by

$$\int_A \frac{\sigma_{\max} y}{d} y dA = M \quad \text{and this gives } \sigma_{\max} = \frac{Md}{I}$$

For any fibre at a distance of y from the centre line we may therefore write

$$\sigma = \frac{My}{I}$$

We therefore have the general equation for pure bending as

$$\frac{\sigma}{y} = \frac{M}{I} = \frac{E}{R}$$

2.1.3.2 Shear stress in bending

In an idealized situation of pure bending of beams, no shear stress occurs across the section. However, in most realistic conditions shear stresses do occur in beams under bending. This can be visualized if we consider the arguments depicted in figure-2.1.3.2.1 and 2.1.3.2.2.

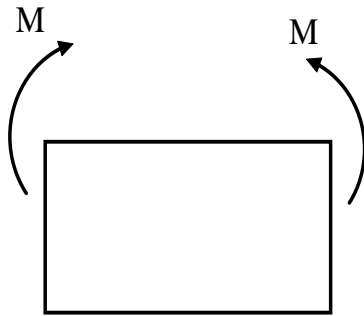

No change in bending moment along the length.

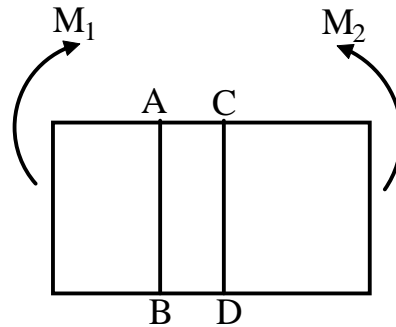

Bending moment changes along the length of the beam

ANIMATE

2.1.3.2.1F- *Bending of beams with a steady and varying moment along its length.*

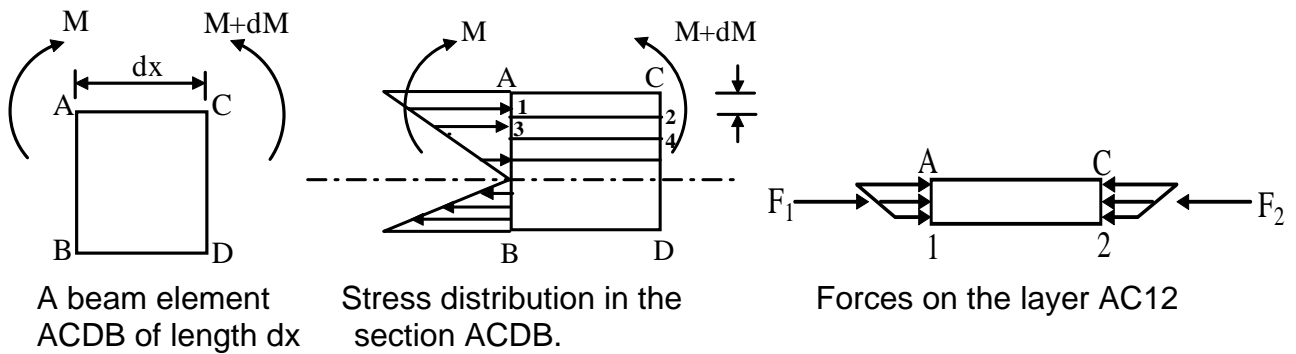

2.1.3.2F- Shear stress developed in a beam subjected to a moment varying along the length

When bending moment changes along the beam length, layer AC12 for example, would tend to slide against section 1243 and this is repeated in subsequent layers. This would cause interplanar shear forces F_1 and F_2 at the faces A1 and C2 and since the $F = \int_A \sigma_x dA$ force at any cross-section is given by , we may write

$$F_1 = \frac{M}{I} Q \quad \text{and} \quad F_2 = \frac{(M + dM)}{I} Q$$

Here M and dM are the bending moment and its increment over the length dx and Q is the 1st moment of area about the neutral axis. Since shear stress across the layers can be given by $\frac{dM}{dx}$ and $\tau = \frac{VQ}{It}$ shear force is given by $V = \tau = \frac{dF}{tdx}$ we may write

2.1.4 Torsion of circular members

A torque applied to a member causes shear stress. In order to establish a relation between the torque and shear stress developed in a circular member, the following assumptions are needed:

1. Material is homogeneous and isotropic
2. A plane section perpendicular to the axis of the circular member remains plane even after twisting i.e. no warping.
3. Materials obey Hooke's law.

Consider now a circular member subjected to a torque T as shown in figure 2.1.4.1

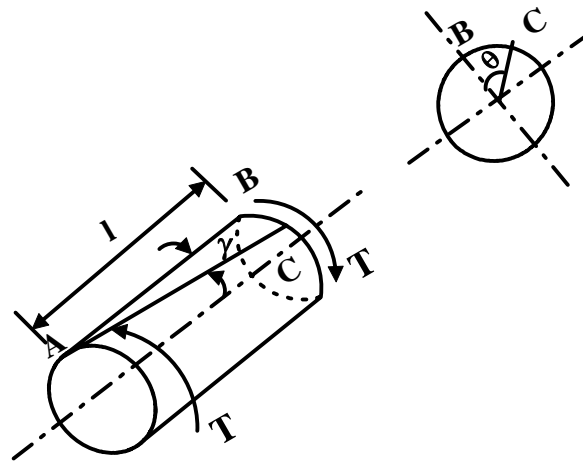

2.1.4.1F- A circular member of radius r and length L subjected to torque T .

The assumption of plane section remaining plane assumes no warping in a circular member as shown in figure- 2.1.4.2

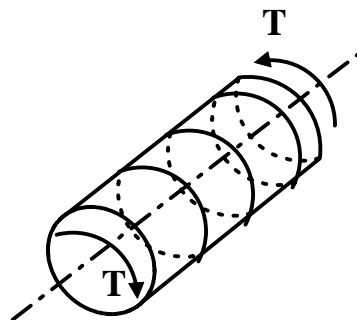

2.1.4.2F- Plane section remains plane- No warping.

However, it has been observed experimentally that for non-circular members warping occurs and the assumption of plane sections remaining plane does not apply there. This is shown in figure-2.1.4.3.

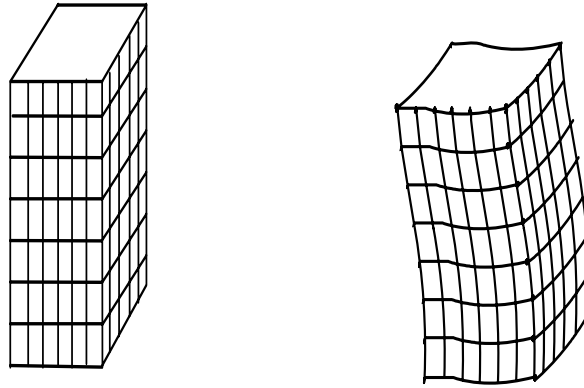

2.1.4.3F-Warping during torsion of a non-circular member.

Let the point B on the circumference of the member move to point C during twisting and let the angle of twist be θ . We may also assume that strain γ varies linearly from the central axis. This gives

$$\gamma l = r\theta \text{ and from Hooke's law } \gamma = \frac{\tau}{G}$$

where τ is the shear stress developed and G is the modulus of rigidity. This gives

$$\frac{\tau}{r} = \frac{G\theta}{l}$$

Consider now, an element of area dA at a radius r as shown in figure-2.1.4.4.

The torque on the element is given by $T = \int \tau r dA$

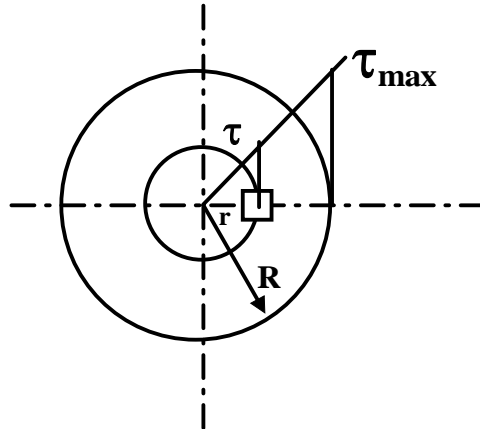

2.1.4.4F- Shear stress variation in a circular cross-section during torsion.

For linear variation of shear stress we have $\frac{\tau}{\tau_{\max}} = \frac{r}{R}$

Combining this with the torque equation we may write

$$T = \frac{\tau_{\max}}{R} \int r^2 dA \quad .$$

Now $\int r^2 dA$ may be identified as the polar moment of inertia J .

And this gives $T = \frac{\tau_{\max}}{R} J$.

Therefore for any radius r we may write in general $\frac{T}{J} = \frac{\tau}{r}$

We have thus the general torsion equation for circular shafts as

$$\frac{T}{J} = \frac{\tau}{r} = \frac{G\theta}{l}$$

2.1.5 Buckling

The compressive stress of P/A is applicable only to short members but for long compression members there may be buckling, which is due to elastic instability.

The critical load for buckling of a column with different end fixing conditions is given by Euler's formula (figure-2.1.5.1)

$$P_{cr} = n \frac{\pi^2 EI}{l^2}$$

where E is the elastic modulus, I the second moment of area, l the column length and n is a constant that depends on the end condition. For columns with both

ends hinged $n=1$, columns with one end free and other end fixed $n=0.25$, columns with one end fixed and other end hinged $n=2$, and for columns with both ends fixed $n=4$.

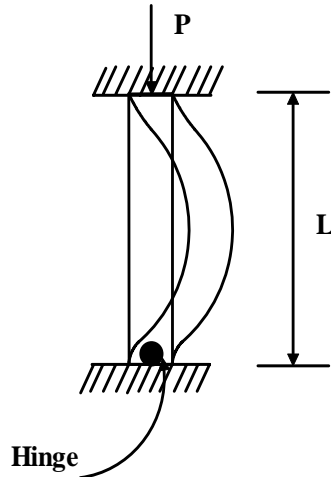

2.1.5.1F- *Buckling of a beam hinged at both ends*

2.1.6 Stress at a point—its implication in design

The state of stress at a point is given by nine stress components as shown in figure 2.1.6.1 and this is represented by the general matrix as shown below.

$$\begin{bmatrix} \sigma_x & \tau_{xy} & \tau_{xz} \\ \tau_{yx} & \sigma_y & \tau_{yz} \\ \tau_{zx} & \tau_{zy} & \sigma_z \end{bmatrix}$$

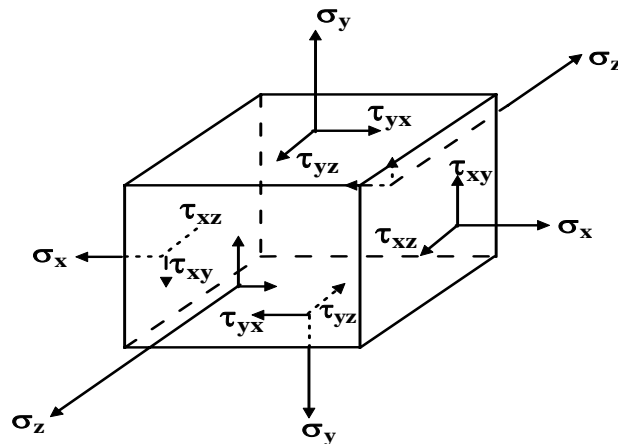

2.1.6.1F- Three dimensional stress field on an infinitesimal element.

Consider now a two dimensional stress element subjected only to shear stresses. For equilibrium of a 2-D element we take moment of all the forces about point A (figure-2.1.6.2) and equate to zero as follows:

$$(\tau_{xy} \delta y \delta z) \delta x - (\tau_{yx} \delta x \delta z) \delta y = 0$$

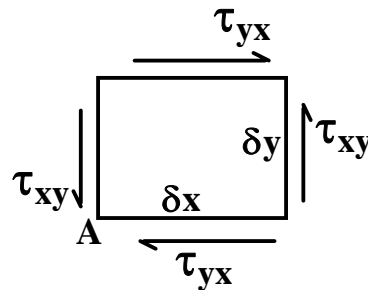

2.1.6.2F- Complimentary shear stresses on a 2-D element.

This gives $\tau_{xy} = \tau_{yx}$ indicating that τ_{xy} and τ_{yx} are complimentary. On similar arguments we may write $\tau_{yz} = \tau_{zy}$ and $\tau_{zx} = \tau_{xz}$. This means that the state of stress at a point can be given by six stress components only. It is important to understand the implication of this state of stress at a point in the design of machine elements where all or some of the stresses discussed above may act.

For an example, let us consider a cantilever beam of circular cross-section subjected to a vertical loading P at the free end and an axial loading F in addition to a torque T as shown in figure 2.1.6.3. Let the diameter of cross-section and the length of the beam be d and L respectively.

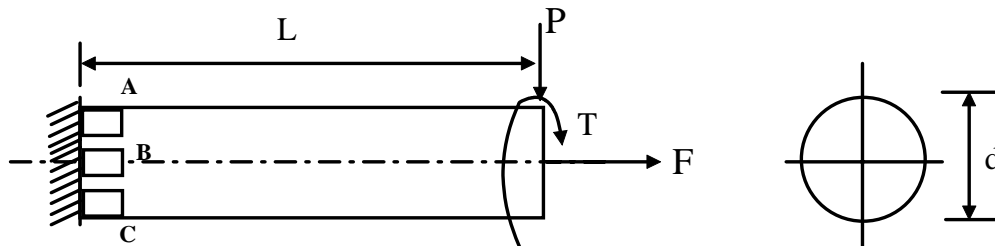

2.1.6.3F- A cantilever beam subjected to bending, torsion and an axial loading.

The maximum stresses developed in the beam are :

$$\text{Bending stress } \sigma_B = \frac{32PL}{\pi d^3}$$

$$\text{Axial stress, } \sigma_A = \frac{4F}{\pi d^2}$$

$$\text{Torsional shear stress } \tau = \frac{16T}{\pi d^3}$$

It is now necessary to consider the most vulnerable section and element. Since the axial and torsional shear stresses are constant through out the length, the most vulnerable section is the built-up end. We now consider the three elements A, B and C. There is no bending stress on the element B and the bending and axial stresses on the element C act in the opposite direction. Therefore, for the safe design of the beam we consider the stresses on the element A which is shown in figure 2.1.6.4.

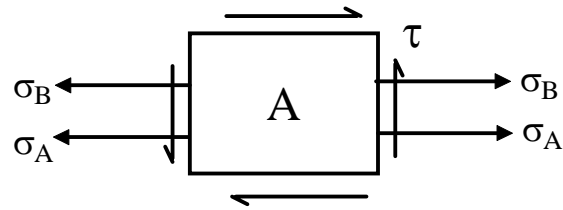

2.1.6.4F- Stresses developed on element A in figure-2.1.6.3

Principal stresses and maximum shear stresses can now be obtained and using a suitable failure theory a suitable diameter of the bar may be obtained.

2.1.7 Problems with Answers

Q.1: What stresses are developed in the pin A for the bell crank mechanism shown in the figure-2.1.7.1? Find the safe diameter of the pin if the allowable tensile and shear stresses for the pin material are 350 MPa and 170 MPa respectively.

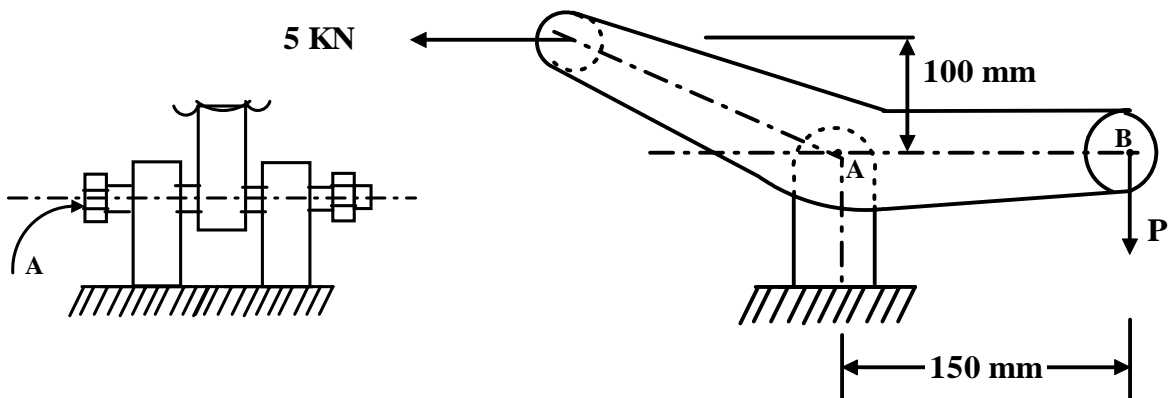

2.1.7.1F

A.1:

$$\text{Force at B} = \frac{5 \times 0.1}{0.15} = 3.33 \text{ kN}$$

$$\text{Resultant force at A} = \sqrt{5^2 + 3.33^2} \text{ kN} = 6 \text{ kN.}$$

Stresses developed in pin A: (a) shear stress (b) bearing stress

$$\text{Considering double shear at A, pin diameter } d = \sqrt{\frac{2 \times 6 \times 10^3}{\pi \times 170 \times 10^6}} \text{ m} = 4.7 \text{ mm}$$

$$\text{Considering bearing stress at A, pin diameter } d = \frac{6 \times 10^3}{0.01 \times 7.5 \times 10^6} \text{ m} = 8 \text{ mm}$$

A safe pin diameter is 10 mm.

Q.2: What are the basic assumptions in deriving the bending equation?

A.2:

The basic assumptions in deriving bending equation are:

- The beam is straight with a constant area of cross-section and is symmetrical about the plane of bending.
- Material is homogeneous and isotropic.
- Plane sections normal to the beam axis remain plane even after bending.
- Material obeys Hooke's law

Q.3: Two cast iron machine parts of cross-sections shown in figure-2.1.7.2 are subjected to bending moments. Which of the two sections can carry a higher moment and determine the magnitude of the applied moments?

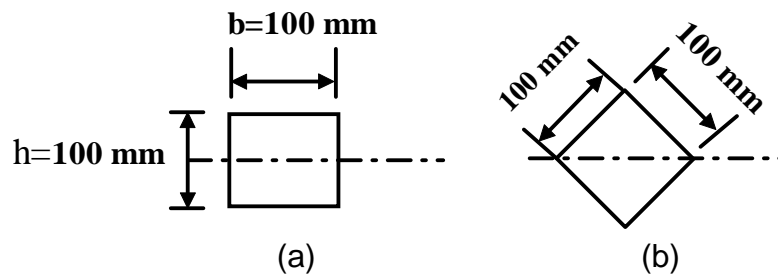

2.1.7.2F

A.3:

Assuming that bending takes place about the horizontal axis, the 2nd moment of areas of the two sections are:

$$I_a = \frac{b \cdot b^3}{12} \qquad I_b = 2 \frac{(\sqrt{2}b) \left(\frac{b}{\sqrt{2}}\right)^3}{36} + 2 \frac{(\sqrt{2}b) \left(\frac{b}{\sqrt{2}}\right)}{2} \left(\frac{b/\sqrt{2}}{3}\right)^2 = \frac{b^4}{12}$$

$$\therefore I_a = I_b$$

Considering that the bending stress σ_B is same for both the beams and moments applied M_a and M_b , we have

$$\sigma_B = \frac{M_a y_a}{I_a} = \frac{M_b y_b}{I_b}$$

Here, $y_a = 0.5b$, $y_b = b/\sqrt{2}$. Then $M_a = \sqrt{2}M_b$

Q.4: Under what condition transverse shear stresses are developed in a beam subjected to a bending moment?

A.4:

Pure bending of beams is an idealized condition and in the most realistic situation, bending moment would vary along the bending axis (figure-2.1.7.3).

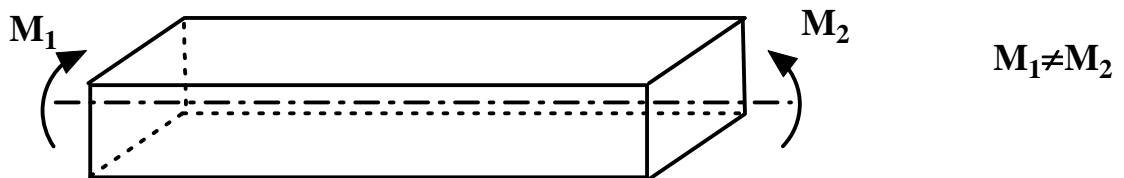

2.1.7.3F

Under this condition transverse shear stresses would be developed in a beam.

Q.5: Show how the transverse shear stress is distributed in a beam of solid rectangular cross-section transmitting a vertical shear force.

A.5:

Consider a beam with a rectangular cross-section (figure-2.1.7.4). Consider now a longitudinal cut through the beam at a distance of y_1 from the neutral axis isolating an area ABCD. An infinitesimal area within the isolated area at a distance y from the neutral axis is then considered to find the first moment of area Q .

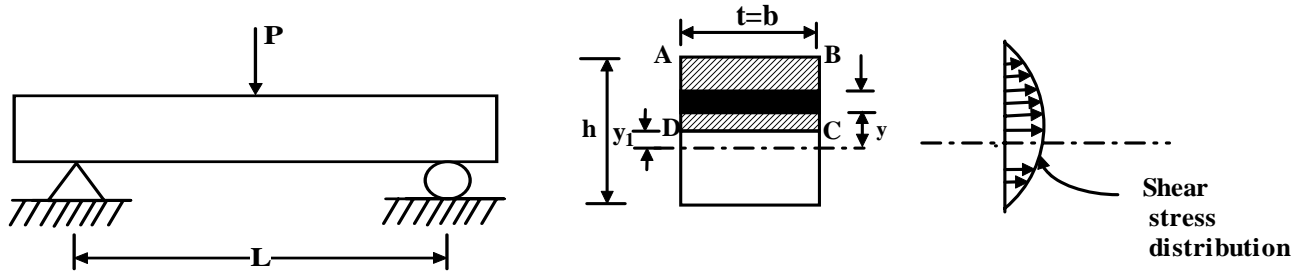

A simply supported beam with a concentrated load at the centre. Enlarged view of the rectangular cross-section

2.1.7.4F

$$\text{Horizontal shear stress at } y, \tau = \frac{VQ}{It} = \frac{V}{It} \int_{y_1}^h b y dy$$

This gives $\tau = \frac{V}{2I} \left[\frac{h^2}{4} - y_1^2 \right]$ indicating a parabolic distribution of shear stress across the cross-section. Here, V is shear force, I is the second moment of area of the beam cross-section, t is the beam width which is b in this case.

Q.6: A 3m long cantilever beam of solid rectangular cross-section of 100mm width and 150mm depth is subjected to an end loading P as shown in the figure-2.1.7.5. If the allowable shear stress in the beam is 150 MPa, find the safe value of P based on shear alone.

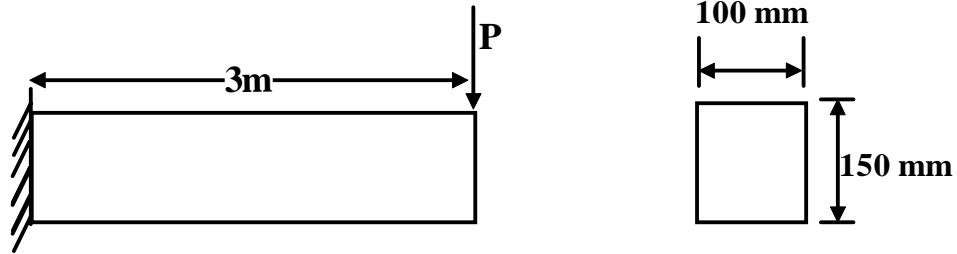

2.1.7.5F

A.6:

Maximum shear stress in a rectangular cross-section is $\tau_{\max} = \frac{3}{2} \frac{V}{A}$

where, A is the cross-section area of the beam.

Substituting values we have $\tau_{\max} = 100P$ and for an allowable shear stress of 150 MPa the safe value of P works out to be 1.5 MN.

Q.7: What are the basic assumptions in deriving the torsion equation for a circular member?

A.7:

Basic assumptions in deriving the torsion formula are:

- Material is homogenous and isotropic.
- A plane section perpendicular to the axis remains plane even after the torque is applied. This means there is no warpage.
- In a circular member subjected to a torque, shear strain varies linearly from the central axis.
- Material obeys Hooke's law.

Q.8: In a design problem it is necessary to replace a 2m long aluminium shaft of 100mm diameter by a tubular steel shaft of the same outside diameter transmitting the same torque and having the same angle of twist. Find the inner radius of the steel bar if $G_{Al} = 28\text{GPa}$ and $G_{St} = 84\text{GPa}$.

A.8:

Since the torque transmitted and angle of twist are the same for both the solid and hollow shafts, we may write from torsion formula

$$\tau_{Al} J_{Al} = \tau_{St} J_{St} \quad \text{and} \quad \frac{\tau_{Al}}{\tau_{St}} = \frac{G_{Al}}{G_{St}}$$

where τ , J and G are shear stress, polar moment of inertia and modulus of rigidity respectively. This gives

$$\frac{d_0^4 - d_i^4}{d_0^4} = \frac{28}{84} \quad \text{and with } d_0 = 100 \text{ mm } d_i = 90.36 \text{ mm}$$

Q.9: An axially loaded brass strut hinged at both ends is 1m long and is of a square cross-section of sides 20mm. What should be the dimension of a steel strut of the same length and subjected to the same axial loads?

A.9:

Considering that both the steel and brass strut would just avoid buckling, we may write

$$\frac{\pi^2 E_{br} I_{br}}{I_{br}^2} = \frac{\pi^2 E_{st} I_{st}}{I_{st}^2}$$

where the suffixes br and st represent brass and steel respectively. Substituting values we have,

$$\frac{I_{br}}{I_{st}} = \frac{200}{90}$$

and this gives sides of the square cross-section of beam strut to be 16.38 mm.

Q.10: Show the stresses on the element at A in figure-2.1.7.6.

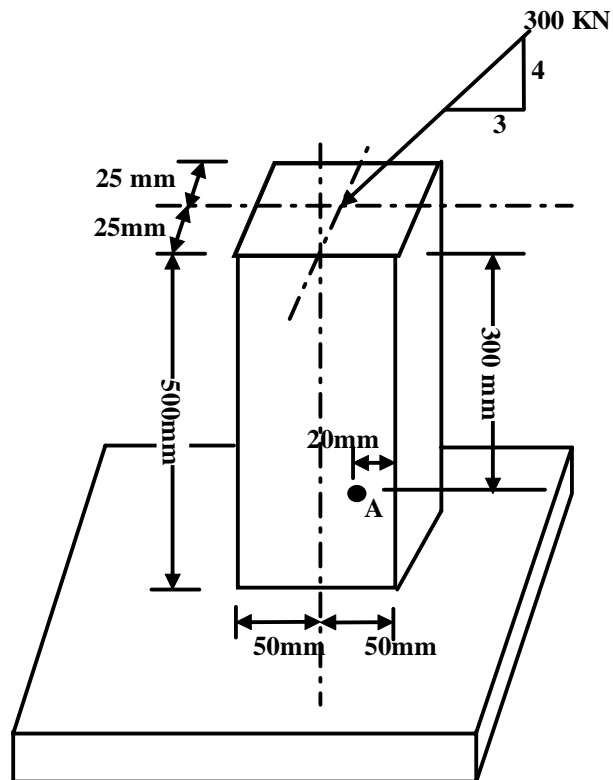

2.1.7.6F

A.10:

The element A is subjected to a compressive stress due to the vertical component 240 kN and a bending stress due to a moment caused by the horizontal component 180 kN.

$$\text{Compressive stress, } \sigma_c = \frac{240}{0.05 \times 0.1} = 48 \text{ MPa}$$

$$\text{Bending (tensile) stress, } \sigma_B = \frac{(180 \times 0.3) \times 0.03}{\left(\frac{0.05 \times 0.1^3}{12} \right)} = 388.8 \text{ MPa}$$

$$\text{Shear stress due to bending} = \frac{VQ}{It} = 8.64 \text{ MPa}$$

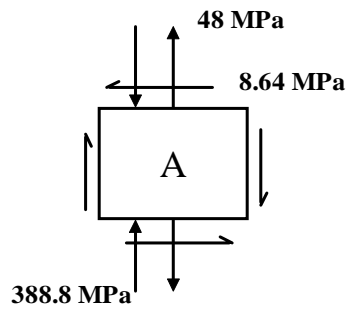

2.1.8 Summary of this Lesson

It is important to analyse the stresses developed in machine parts and design the components accordingly. In this lesson simple stresses such as tensile, compressive, bearing, shear, bending and torsional shear stress and buckling of beams have been discussed along with necessary formulations. Methods of combining normal and shear stresses are also discussed.